

## ROTARY COOLANT ADAPTERS

### Collet chuck type

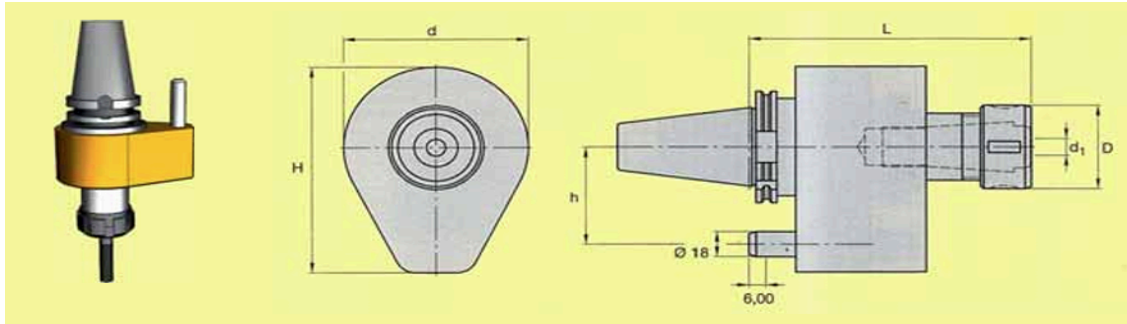

Catalogue No.	d1	L	D	H	d	h	Max. RPM	Weight in Kg.
BT40RER32155M	2 to 20	155	50	146	110	65	5000	6.5
BT40RDA188165M	3 to 20	165	43	135	96	65	5800	7.7
BT40RTG100175M	3 to 25.5	175	60	146	110	65	5000	6.5
BT50RER40185M	3 to 26	185	63	162	112	80	5000	9.5
BT50RTG100185M	3 to 25.5	185	60	162	112	80	5000	9.5

Order Example : BT40RER32155M

Scope of Supply : Basic Tool Holder, Locknut, Stopscrew  
 Accessories : To be ordered separately  
 ER Collets : Page No.  
 Pull Stud : Page No.  
 All details are subject to change without Notice

## ROTARY COOLANT ADAPTERS

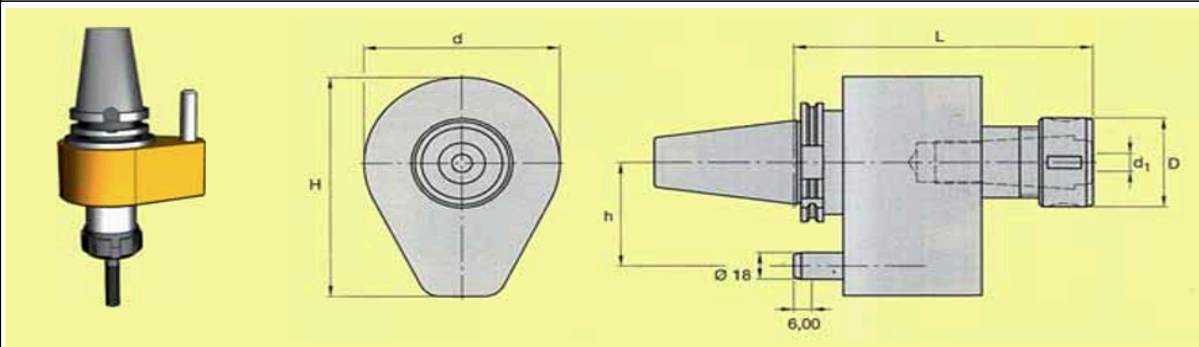

Catalogue No.	d1	L	D	H	d	h	Max. RPM	Weight in Kg.
DV40RDA188165M	3 to 20	165	43	135	96	65	5800	7.7
DV40RTG100175M	3 to 25.5	175	60	146	110	65	5000	6.5
DV50RTG100185M	3 to 25.5	185	60	162	112	80	5000	9.5

Order Example : DV50RTG100185M

Scope of Supply : Basic Tool Holder, Locknut, Stopscrew  
 Accessories : To be ordered separately  
 DA / TG Collets : Page No.  
 Pull Stud : Page No.  
 All details are subject to change without Notice

## ROTARY COOLANT ADAPTERS

### End mill type

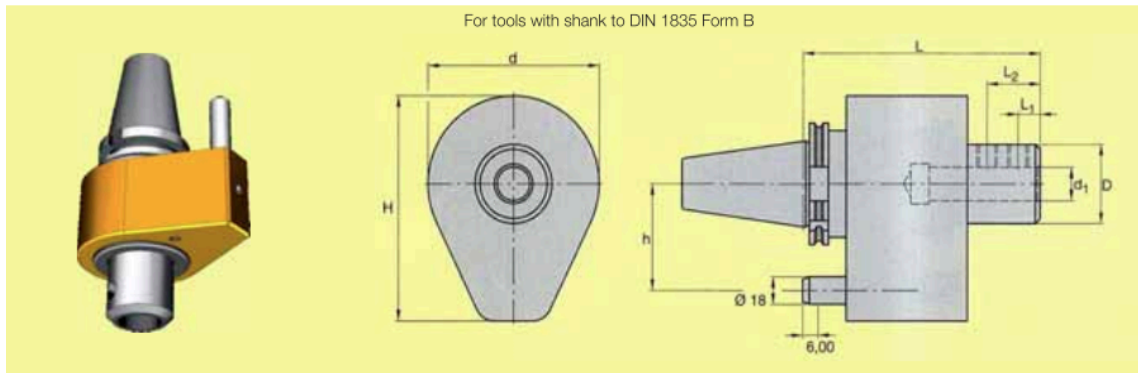

Catalogue No.	d1	L	D	H	d	h	L1	L2	Max. RPM	Weight in Kg.
BT40REM16150M	16	150	40	127	80	65	13	-	6500	3.9
BT40REM20150M	20	150	40	127	80	65	13	---	6500	3.9
BT40REM25150M	25	150	40	127	80	65	15	-	6500	3.9
BT40REM32155M	32	155	50	133.5	94	65	16	---	5800	4.6
BT40REM40170M	40	170	60	146	110	65	16	35	5000	5.2
BT50REM16155M	16	155	50	152.5	96	80	13	--	5800	7.7
BT50REM20155M	20	155	50	152.5	96	80	13	--	5800	7.7
BT50REM25160M	25	160	50	152.5	96	80	15	--	5800	7.7
BT50REM32175M	32	175	60	161	112	80	16	--	5000	8.7
BT50REM40175M	40	175	60	161	112	80	16	35	5000	8.7
BT50REM50180M	50	180	70	166	114	80	16	35	4500	9.5

Order Example : BT50REM50180M

Scope of Supply : Basic Tool Holder, Lockscrews  
 Accessories : To be ordered separately  
 Pull Stud : Page No.  
 All details are subject to change without Notice

## ROTARY COOLANT ADAPTERS

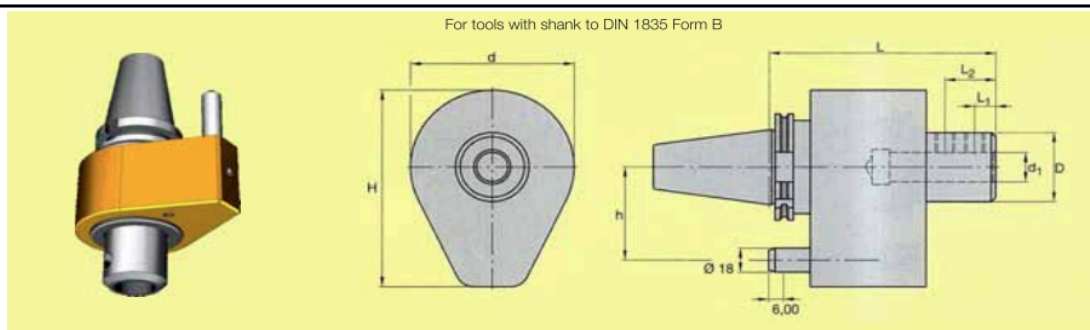

Catalogue No.	d1	L	D	H	d	h	L1	L2	Max. RPM	Weight in Kg.
DV40REM16150M	16	150	40	127	80	65	13	---	6500	3.9
DV40REM20150M	20	150	40	127	80	65	13	---	6500	3.9
DV40REM25150M	25	150	40	127	80	65	15	---	6500	3.9
DV40REM32155M	32	155	50	133.5	94	65	16	-	5800	4.6
DV40REM40170M	40	170	60	146	110	65	16	35	5000	5.2
DV50REM16155M	16	155	50	152.5	96	80	13	---	5800	7.7
DV50REM20155M	20	155	50	152.5	96	80	13	---	5800	7.7
DV50REM25160M	25	160	50	152.5	96	80	15	--	5800	7.7
DV50REM32175M	32	175	60	161	112	80	16	-	5000	8.7

DV50REM40175M	40	175	60	161	112	80	16	35	5000	8.7
DV50REM50180M	50	180	70	166	114	80	16	35	4500	9.5
Order Example : DV50REM25160M				Scope of Supply : Basic Tool Holder, Lockscrews Accessories : To be ordered seperately Pull Stud : Page No. All details are subject to change without Notice						